

1994-ON K1100LT FRAME

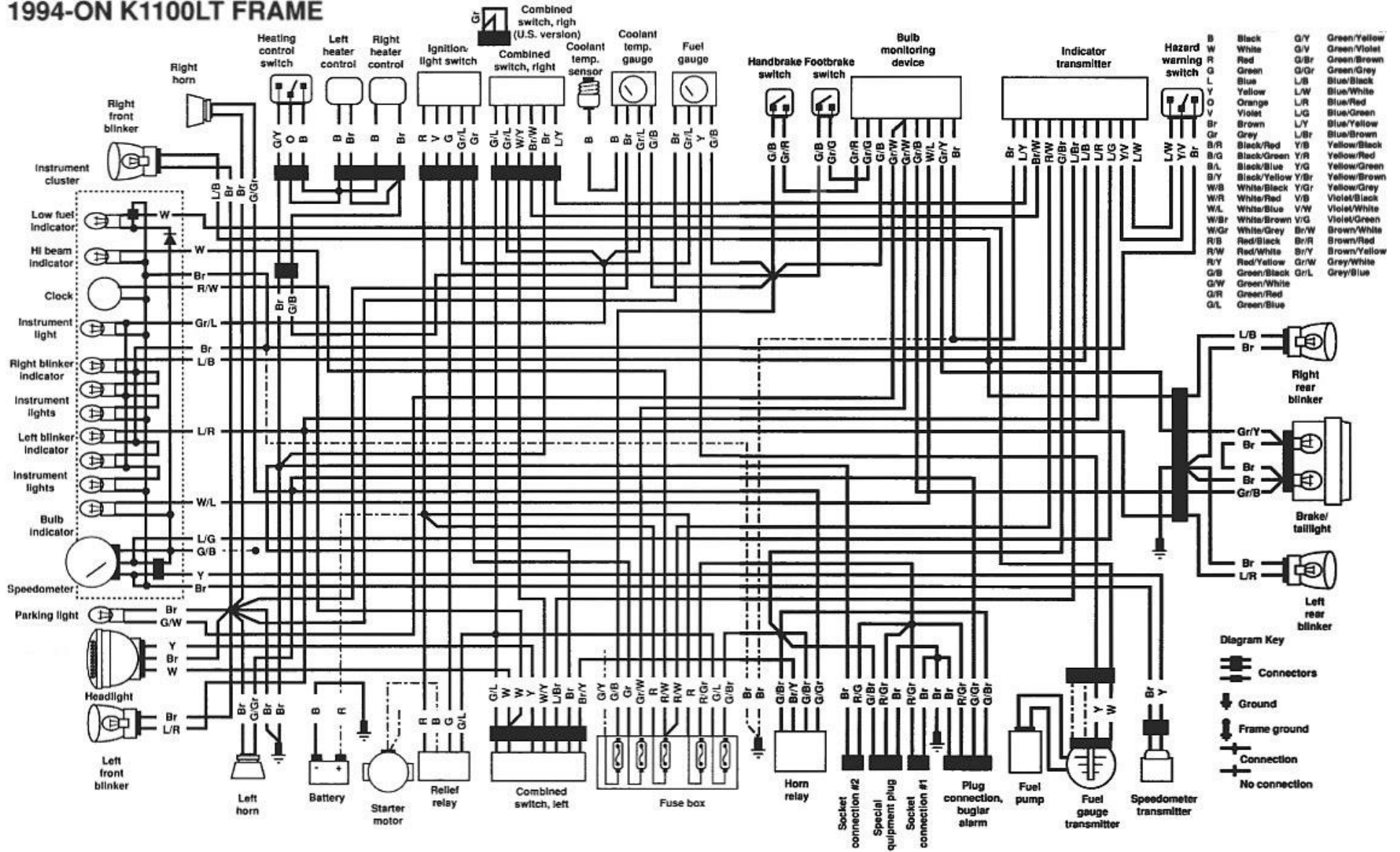

1994-ON K1100 A B S

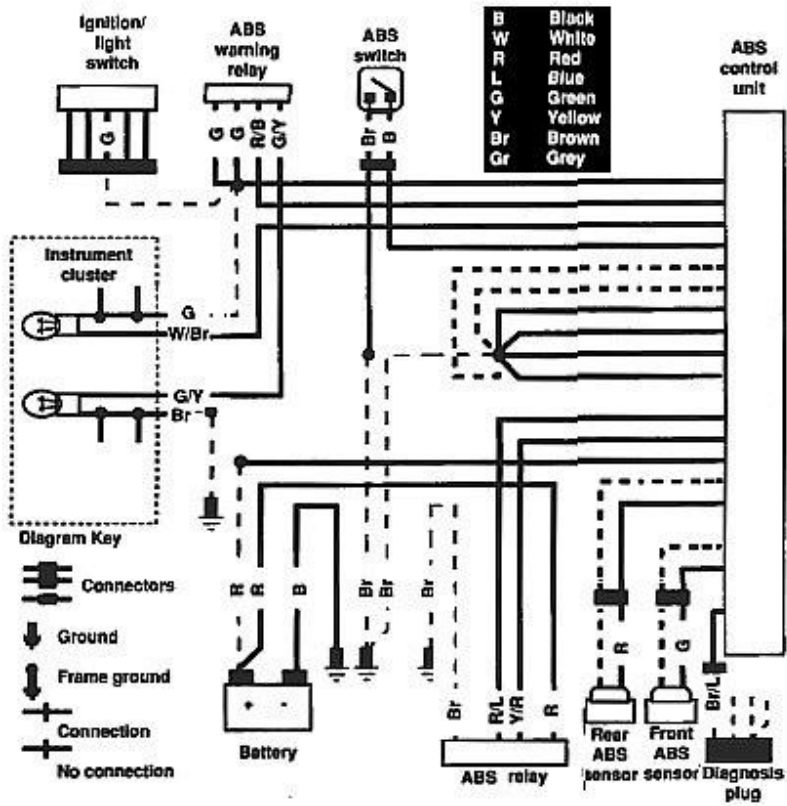

1993-ON K1100RS, K1100LT HEATED HANDLEBAR GRIP CIRCUIT

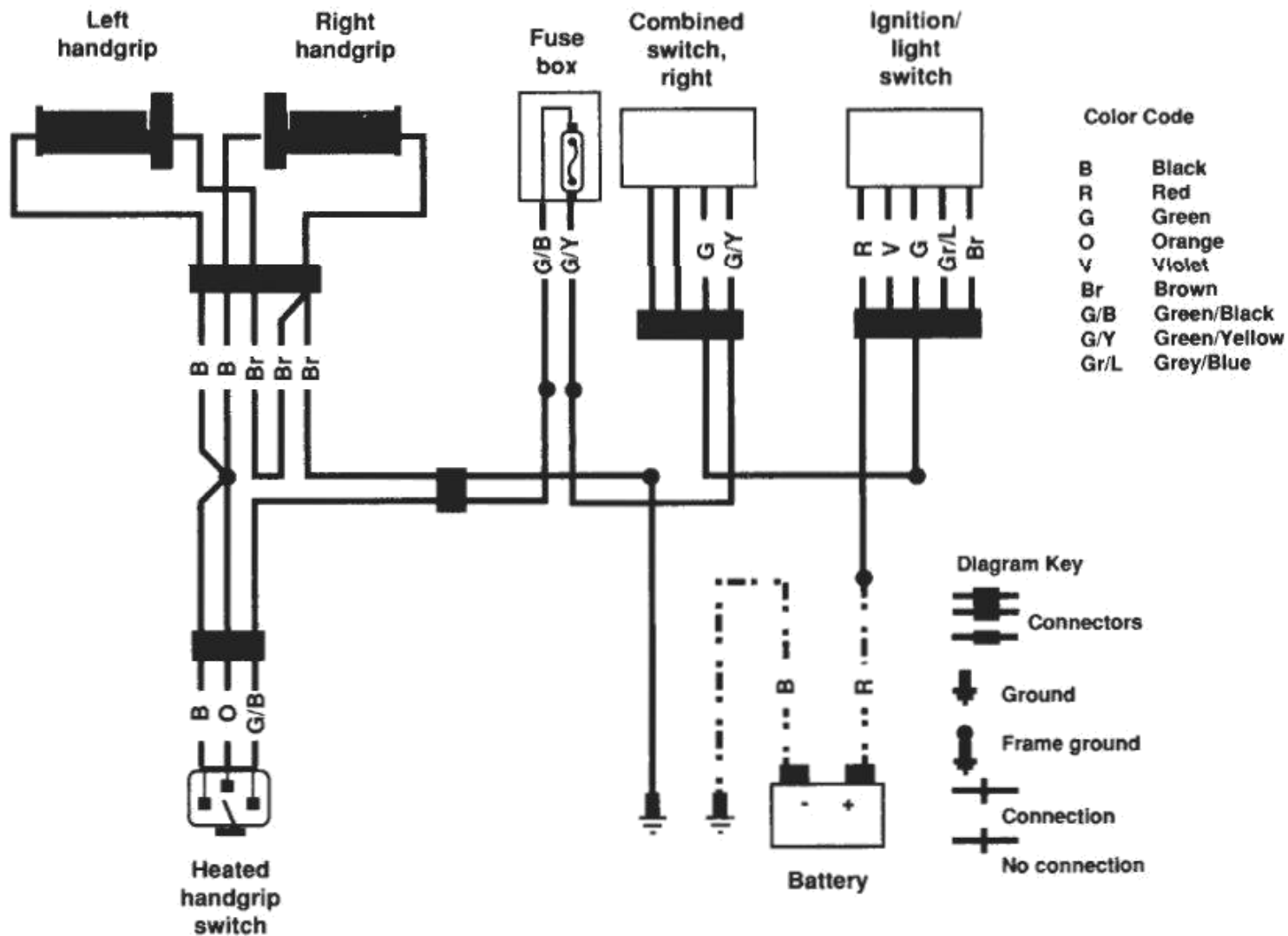

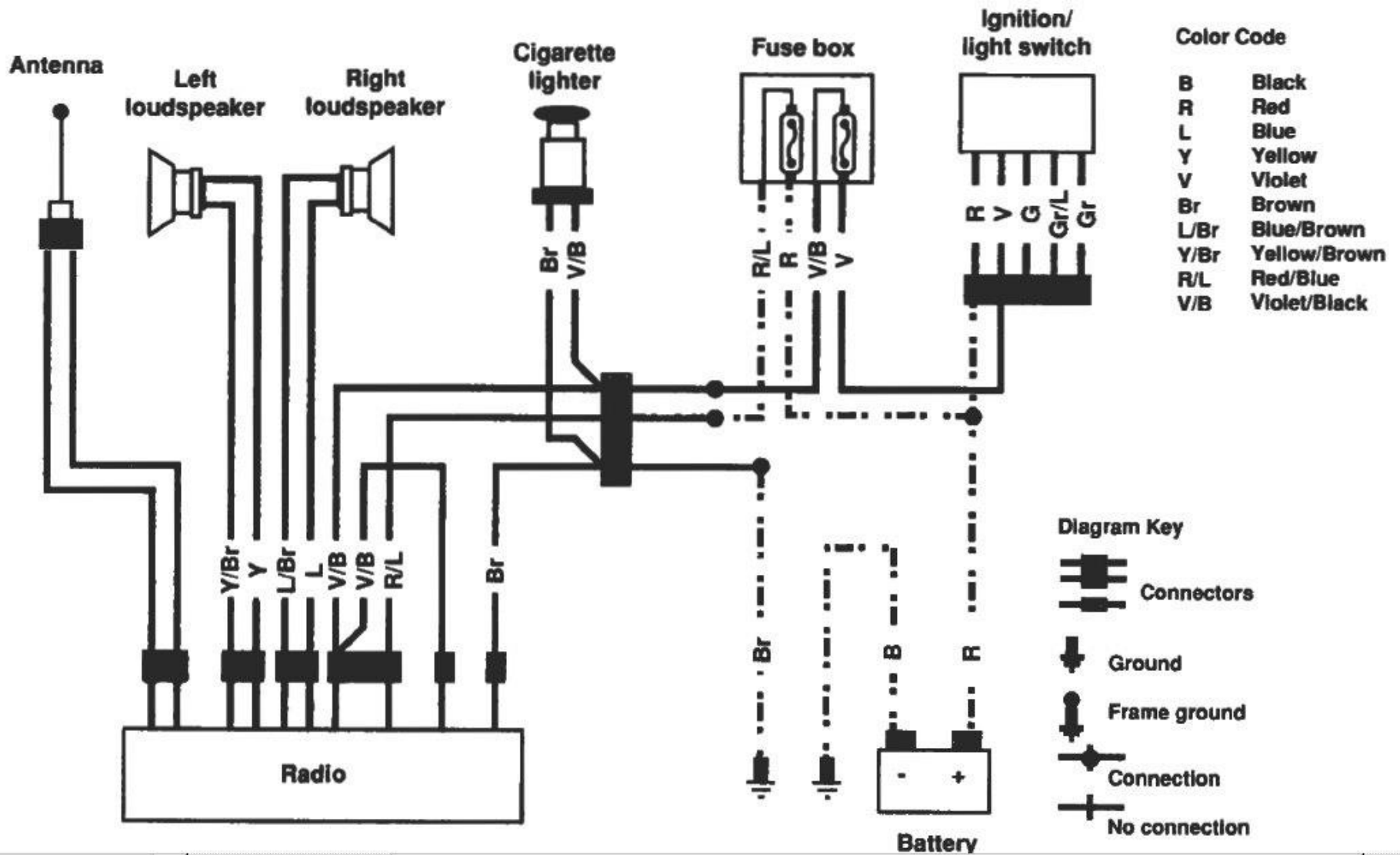

- 1 Radio receiver
- 2 Connection electronics radio
- 3 Aerial booster
- 4 Loudspeaker, left
- 5 Loudspeaker, right
- 6 Connection wiring harness
- 7 bulb monitoring unit
- 8 Fuse 2
- 9 Fuse 5
- 10 ignition lock
- 11 starter relay
- 12 battery

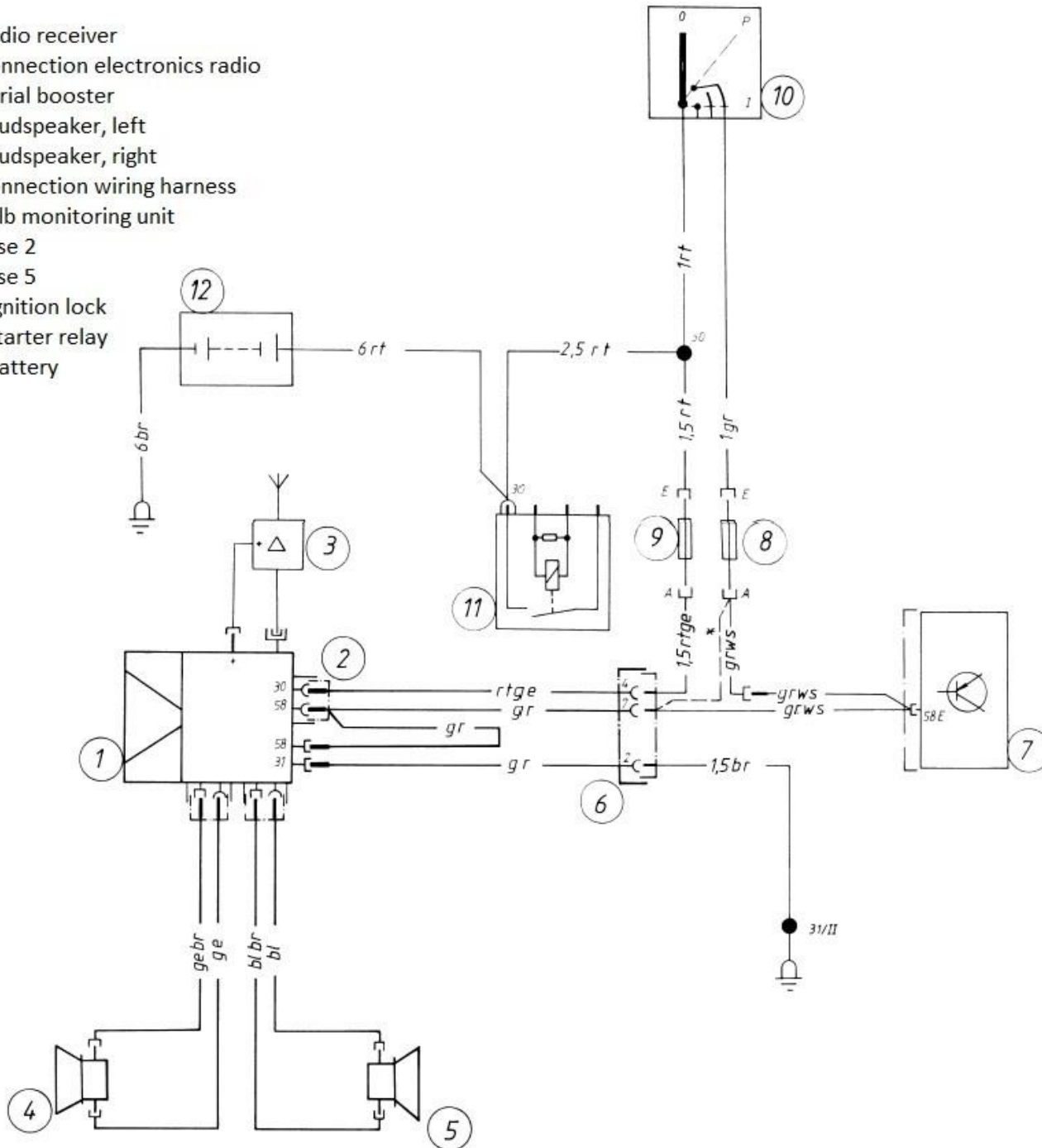



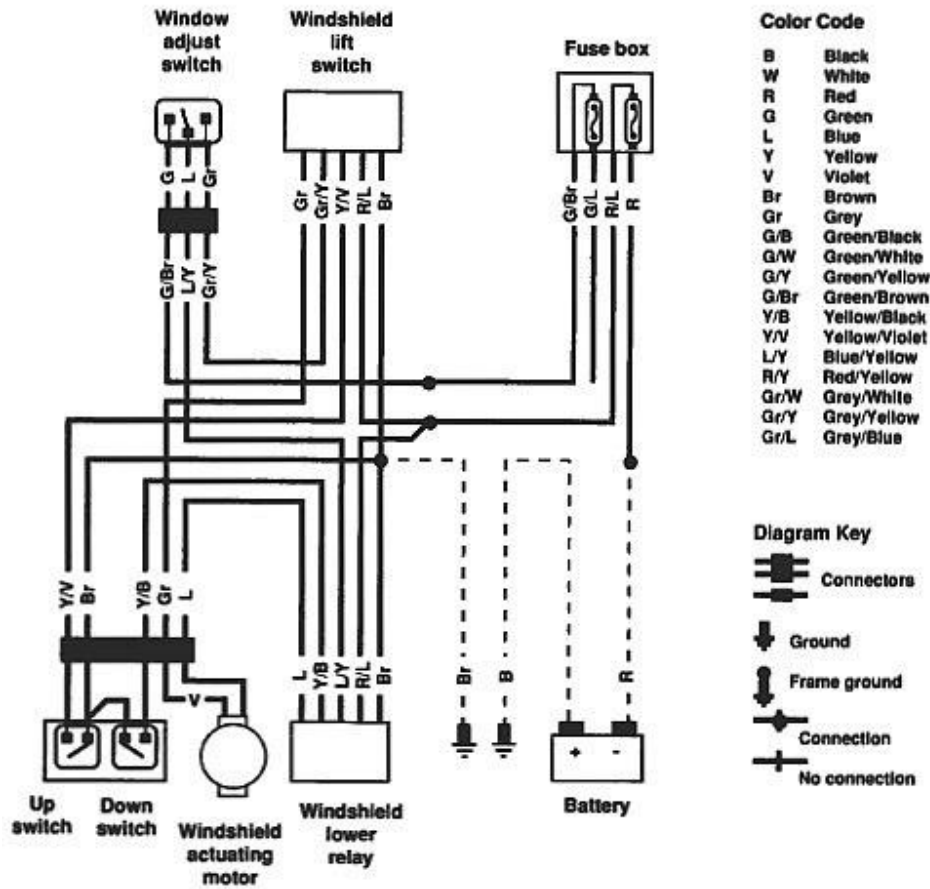

1994-ON K1100LT WINDSHIELD CIRCUIT



Color Code

B	Black
W	White
R	Red
G	Green
L	Blue
Y	Yellow
V	Violet
Br	Brown
Gr	Grey
G/B	Green/Black
G/W	Green/White
G/Y	Green/Yellow
G/Br	Green/Brown
Y/B	Yellow/Black
Y/V	Yellow/Violet
L/Y	Blue/Yellow
R/Y	Red/Yellow
Gr/W	Grey/White
Gr/Y	Grey/Yellow
Gr/L	Grey/Blue

Diagram Key

-  Connectors
-  Ground
-  Frame ground
-  Connection
-  No connection

1993-ON K1100LT READING LAMP CIRCUIT

